

# FORGED PISTON CHECK VALVE BOLTED BONNET 800# NPT/SW



Fig. 4611

## Features

Design	API 602 Bolted bonnet
Rating	800#
Face to face	According to dimension table
Ends	SW. NPT Threaded

## Materials

N°	Part name	Material
1	Body	A105 / A182 F316
2	Seat	A105 + STL / A182 F316+STL
3	Piston	A182 F6A + STL / A182 F316 + STL
4	Gasket	AISI 304 + Graphite / AISI 316 + Graphite

## Main dimensions

Size		L	H	Weight Kg
DN	NPT			
15	½"	79	62	1,2
20	¾"	92	63	1,4
25	1"	111	78	2,3
32	1¼"	120	82	3,9
40	1½"	152	102	5,6
50	2"	172	120	8,9

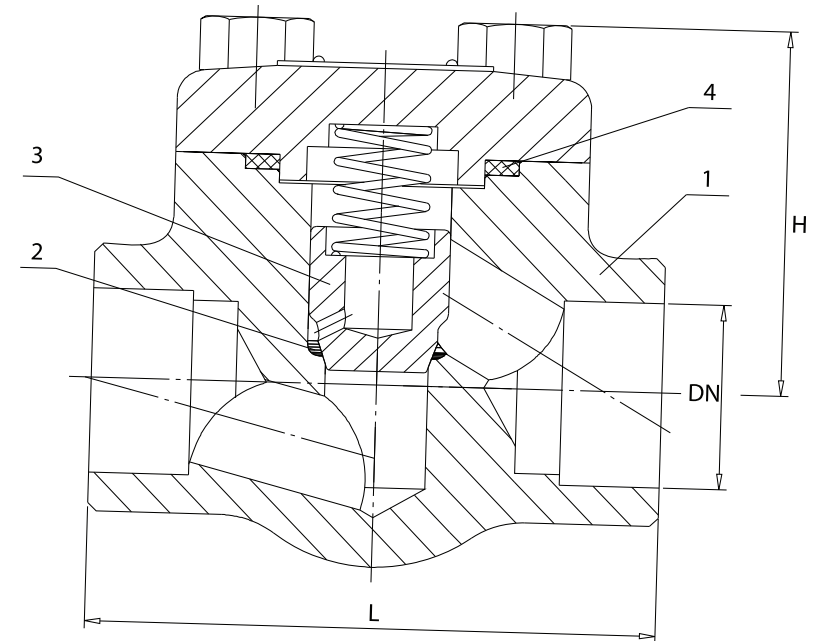

# FORGED PISTON CHECK VALVE PRESSURE SEAL 1500#/2500# SW



Fig. 4671

## Features

Design	ASME B16.34. Pressure seal bonnet
Rating	1500# / 2500#
Face to face	According to dimension table
Ends	SW / NPT / BW

## Materials

N°	Part name	Material
1	Body	A105 / A182 F316
2	Seat	A105+ STL/ A182 F316 + STL
3	Disc	A182 F6A / A182 F316
4	Gasket	AISI 304 / AISI 316

## Main dimensions

Size		L		H		Weight Kg	
DN	NPT	1500#	2500#	1500#	2500#	1500#	2500#
15	½"	140	186	117	117	7,5	11,8
20	¾"	140	186	117	117	7,0	11,0
25	1"	140	186	117	117	6,8	10,5
32	1¼"	178	232	152	152	18,5	23,0
40	1½"	178	232	152	152	20,3	26,4
50	2"	216	276	195	195	22,0	39,0

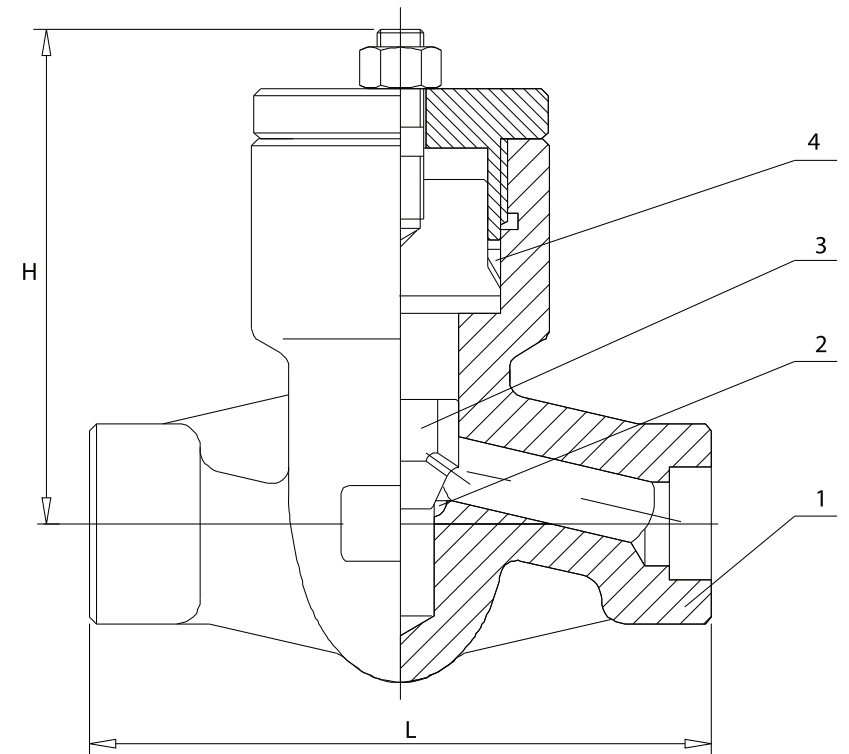

# FORGED PISTON CHECK BOLTED BONNET 150#/300#/600# ANSI FLANGED



Fig. 4415

## Features

Design	API 602 Bolted bonnet
Rating	150# / 300# / 600#
Face to face	ASME B16.10
Ends	ANSI Flanged

## Materials

N°	Part name	Material
1	Body	A105 / A182 F316
2	Disc	A182 F6A + STL / A182 F316 + STL
3	Gasket	AISI 304 + Graphite / AISI 316 + Graphite

## Main dimensions

Size		H		L			Weight Kg		
DN	NPS	150#	300# / 600#	150#	300#	600#	150#	300#	600#
15	½"	77	61	108	152	165	3,6	3,7	4,0
20	¾"	81	78	117	178	190	4,6	4,8	5,8
25	1"	93	84	127	203	216	8,5	8,8	9,5
32	1¼"	95	101	140	216	229	9,2	9,6	10,4
40	1½"	103	120	165	229	241	12,5	13,7	15,6
50	2"	118	133	203	267	292	14,8	17,8	24,5

